

Assessment of Rough Bed Length Variations on the Hydraulic Jump Features

B. Ghorbani, M. Bazaz

Abstract- One of the practical applications of hydraulic jump is to dissipate in energy water flowing over hydraulic structures and thus prevent scouring downstream from them. In the recent years, it was found that the roughness of stilling basins can reduce the dimensions of hydraulic jump features. The objective of this study was to find out how the rough bed length effects on these features. To find the effect of roughness length on jump properties, 5 lengths of roughness and 4 types of roughness for 4 different Froude numbers were investigated. Four extra tests were performed on the smooth bed as witness to understand and compare the jump features on the same conditions. The results showed that the jump features such as jump length and sequent depth declines and shear stress increases as the roughness length increases to a value equals to effective length. The effective length obtained in this research was 2.5 times of sequent depth on the smooth bed. Overall, the mean sequent depth and hydraulic jump length on a rough bed reduced by 14 and 29 percent respectively and shear stress increased by 8.11 times compare to that of the smooth bed.

Keywords: Effective length, hydraulic jump, jump length, rough bed, sequent depth

I. INTRODUCTION

Hydraulic jump is a phenomenon in which the supercritical depth changes to subcritical depth. One of the practical applications of hydraulic jump is to dissipate in energy water flowing over the hydraulic structures such as spillways, shuts and sluice gates and thus prevent scouring downstream from them. Surface waves, turbulence flow and high flow velocity of a hydraulic jump cause irrigation facilities in the area to be placed at the risk of degradation and erosion. Due to this fact, the hydraulic structures should be resistant that in turn causes high cost of construction. On the other hand, as the Froude number increases to values beyond 10, a hydraulic jump may no longer be the most economical dissipation way. In this case, a very deep basin with high retaining wall is required. Therefore, extensive efforts have been used to perform applied research to generate jumps with smaller dimensions and lower cost. USBR (1987) has suggested the length of jump to be 6 times of sequent depth on smooth bed. According to Belanger, a hydraulic jump will form in the channel, if the Froude number (Fr_1) of the flow, the depth (y_1) and a downstream depth (y_{co}) satisfy the following equation (chow 1956):

$$y_{co} = \frac{1}{2}y_1 \left[\sqrt{1 + 8Fr_1^2} - 1 \right] \quad \text{Eq. (1)}$$

Revised Version Manuscript Received on July 25, 2015.

B. Ghorbani, Assoc. Prof., Department of Water Engineering, Shahrekord University, Shahrekord, Iran.

M. Bazaz, Formerly M.Sc. Student, Department of Water Engineering, Shahrekord University, Shahrekord, Iran.

Standard stilling basins are the hydraulic structures that include accessories such as chute blocks, baffle piers and end sills that cause more energy dissipation and reduce jump features dimensions. The function of chute blocks is to furrow the incoming jet and lift a portion of it from the floor and shorten the length of the jump. The function of sill is to reduce further the length of the jump and to control scour. The hydraulic jump can be controlled by sills of various designs, such as abrupt rise, sharp crested weir, broad crested weir and drop in channel. End sill insures the formation of jump and controls its position under all probable operating conditions. Baffle piers, which are placed in intermediate positions across the basin, can dissipate energy mostly by impact action. However, these are unsuitable, where high velocities make cavitation possible (1987). In the recent years, the investigators have found roughening the stilling basins can help to reduce the dimensions of hydraulic jump features. To roughen the bed means to modify the bed surface into different shapes such as triangle, trapezoid, sinuses shapes and so on. One of the main characteristics of rough bed is resemble roughness at the same level of channel bed located at the upstream and downstream of hydraulic jump position. This will prevent cavitation which is one of the difficulties of standard stilling basins at high flow velocities. A study by Rajaratnam's (1968) showed that the continuous triangle roughness reduces the size of jump length and sequent depth considerably, which was confirmed by the other researchers later, for instance, Ead and Rajaratnam (2002). They reported the rough bed with the height of 2.5 centimeters will reduce jump length by 50 percent and sequent depth by 25 percent with respect to smooth bed in the range of Froude number 4 to 10. Izadjoo and Shafai Bejestan (2007) reported that the jump length reduced by 50 percent and sequent depth reduced by 20 percent affected by trapezoidal wavy rough bed under the range of Froude number 4 to 12. These investigations were approved by others, such as Abbaspour et al. (2009) and Tokyay (2005). Sun and Ellayn (2012) reported that prismatic staggered rough beds are more effective on the reduction of jump dimensions than strip rough bed. This investigation showed that the prismatic staggered rough bed reduced sequent depth and length of jump by 14 to 40 and 56 percent respectively. Also Azizah et al. (2012) showed that U-shape rough bed elements reduced dimensions of jump more than cubic shape. Therefore, from these studies, it may be concluded that roughening of the bed is one of the effective approaches to control the jump features. Abbaspour et al. (2013) used Artificial neural networks (ANNs) and genetic programming (GP) to estimate the characteristics of hydraulic jumps,



Assessment of Rough Bed Length Variations on the Hydraulic Jump Features

such as the jump depth, jump length, and energy dissipation, as functions of the Froude number and the height and length of corrugations. The results of the ANN model were compared with those of the GP model, showing that the proposed ANN models are much more accurate than the GP models. The previous investigators, focused on the effect of fully rough bed on the jump features, performed several experiments. In the present research, however, the objective was to assess the effect of length of roughness on the jump characteristics and ultimately to suggest suitable relationship for the jump features verses the variations of roughness length. Further investigations on the length of roughness, sequent depth and effective rough length were carried out. The effective rough length is a length by which no more effect on the jump characteristics will be considered by increasing the rough length. This factor was also evaluated, for every feature of jump including jump length and sequent depth, in this study.

II. MATERIALS AND METHODS

The experiments were carried out at the Hydraulic Laboratory of Water Engineering Department of Shahrekord University, Iran. A Plexiglas flume with 12 meters in length, 40 cm in depth and 40 cm in width were used for this experimental purpose. The Plexiglas flume provided easy observation of jump features and behavior. Water was pumped from a reservoir into an initial storage located at the beginning of the flume, by a centrifugal pump. Three metal mesh screens were used in the initial storage to calm the turbulence flow before entering the flume. An overflow weir located at the end of the flume was used to control the tail-water depth in the flume. As water runs over the weir, enters into a pond and flows into the reservoir by gravity force. Figure1 shows the schematic diagram of experimental flume. An underflow vertical sluice gate with 90 cm height was used to produce hydraulic jump. This gate caused upstream subcritical water depth to be changed to supercritical depth over the downstream mild sloped flume bed. Mild slope tends to change water depth from supercritical to subcritical depth through a hydraulic jump. A variety of hydraulic jumps was generated by changing the sluice gate opening with different Froude numbers. The position of the jump was controlled by changing the tail water depth via changing the angle of weir located at the end of flume. The length of a jump (L_j) is the distance measured from the front face of the jump to the point on the surface immediately downstream from the roller, where the depth of water equals to the tail water. This was measured empirically in the lab. The sequent depth (y_2) was measured at a point after the jump where there was no change in water depth.

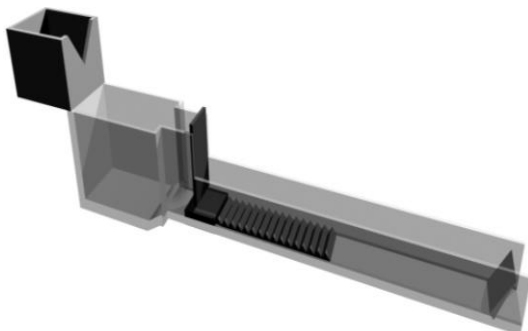

Fig. I. A schematic figure of experimental flume

In order to find the effective length of roughness, the impact of 5 roughness lengths on the jump features was investigated. For this purpose, the length of roughness increased to a value where no change was observed in the jump features. A galvanized smooth metal plate installed in a horizontal groove was used to change the length of roughness by sliding and putting it on a part of rough surface which was out of use. Figure2 shows the experimental set up to study the roughness variations along the channel bed. During the experiments, the hydraulic jump shifted toward the sluice gate as the length of roughness increased. To fix it again on its previous position, therefore, it was necessary to reduce the tail water depth using the overflow weir installed at the end of flume. The measurements were performed in a manner that the beginning of the jump coincides with the beginning of rough bed. All the tests were carried out in the range of 5.83 to 10.13 Froude number and the flow rates 19.7 to 33.2 l/s. Triangular wavy roughness, as indicated in Figure3, was selected to make 4 rough beds to do the experiments. As shown in this figure, the upstream side slope of triangle was chosen to be steeper than its downstream side slope. As indicated in Table 2, the length of roughness waves was selected to be in the range of 5.5 to 13 cm and their heights to be 1.5 cm. The experiments features including initial depth (y_1), flow rate (Q) and the length of roughness (L_{rou}) are shown in Table 1. Four triangular roughness shapes were used in this study. The tests were carried out for 4 Froude numbers, 4 roughness types and 5 lengths of roughness. As indicated in Table 1, 20 tests were conducted over each roughness from A to D, to get a total of 80 tests. Further tests, as indicated in Table 3, also were performed for 4 Froude numbers on the smooth bed as control.

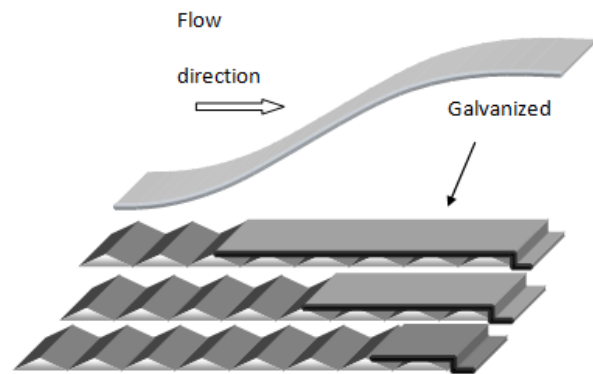

Fig. II. A schematic of changing manner of roughness length

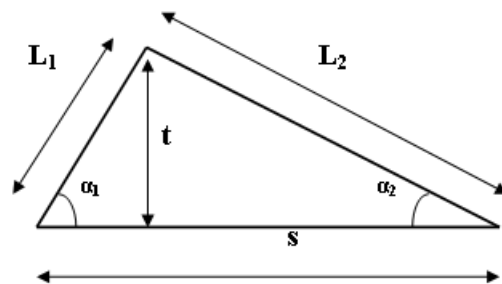

Fig. III. Triangular shape used in roughness experiments

Table I. The characteristics of experiments

Fr ₁	y ₁ (cm)	Q (m ³ /s)	NO	L _{rou} (cm)	NO	L _{rou} (cm)	NO	L _{rou} (cm)	NO	L _{rou} (cm)
8.94	1.5	0.019	A1	8	B1	12	C1	15	D1	17
			A2	14	B2	20	C2	26	D2	31
			A3	27	B3	38	C3	36	D3	44
			A4	38	B4	55	C4	60	D4	70
			A5	50	B5	62	C5	72	D5	83
10.13	1.5	0.023	A6	8	B6	12	C6	15	D6	17
			A7	20	B7	20	C7	26	D7	31
			A8	32	B8	30	C8	36	D8	44
			A9	44	B9	46	C9	60	D9	70
			A10	62	B10	62	C10	72	D10	83
5.83	2.5	0.026	A11	14	B11	11	C11	15	D11	17
			A12	26	B12	20	C12	26	D12	31
			A13	38	B13	29	C13	36	D13	57
			A14	50	B14	46	C14	60	D14	84
			A15	62	B15	53	C15	71	D15	97
7.26	2.5	0.033	A16	14	B16	11	C16	15	D16	17
			A17	25	B17	20	C17	26	D17	31
			A18	38	B18	38	C18	47	D18	57
			A19	56	B19	56	C19	71	D19	84
			A20	68	B20	63	C20	91	D20	97

Table II. Characteristics of rough sheets with height, $t = 1.5$ cm, used in this study

Row	Sheets	s (cm)	L ₁ (cm)	α ₁ (deg)	L ₂ (cm)	α ₂ (deg)
1	A	5.5	2.5	36	3.8	23
2	B	8.5	3.4	26	5.7	15
3	C	11	4.3	20	7.6	12
4	D	13	5.2	16	8.1	10

Table III. Control tests characteristics

NO	Fr ₁	y ₁	L _{jco}	y _{co}
*CO1	8.94	1.5	75	17.5
CO2	10.13	1.5	88	20.4
CO3	5.83	2.5	70	18.2
CO4	7.2	2.5	100	23.6

Note: * CO stands for control, L_{jco} = jump length on smooth bed, y_{co} = sequent depth on smooth bed

III. RESULTS AND DISCUSSION

A. Theory

Dimensional analysis was performed to find a relationship indicating the effect of factors on the sequent depth of hydraulic jump as follows:

$$y_2 = f_1(y_1, u_1, g, \mu, \rho, s, t, L_{rou}) \quad \text{Eq. (2)}$$

where, y₂ is sequent depth, y₁ and u₁ are initial supercritical depth and velocity respectively, L_{rou} is roughness length, s is

the length of roughness wave, t is height of roughness, ρ is fluid density, μ is dynamic viscosity and g is gravity factor.

On the base of Buckingham theorem, the following formula was derived:

Assessment of Rough Bed Length Variations on the Hydraulic Jump Features

$$\frac{y_2}{y_1} = f_2\left(\text{Re} = \frac{u_1 y_1}{\nu}, \text{Fr}_1 = \frac{u_1}{\sqrt{g y_1}}, \frac{t}{y_1}, \frac{s}{y_1}, \frac{L_{\text{rou}}}{y_1}\right)$$

Eq (3)

In this study, the values of Reynolds Numbers were in the range of 51209 to 89514. This means, the flow was turbulent and the effect of viscosity is ignored. Therefore, the following function was derived:

$$\frac{y_2}{y_1} = f_3\left(\text{Fr}_1, \frac{t}{y_1}, \frac{s}{y_1}, \frac{L_{\text{rou}}}{y_1}\right)$$

Eq. (4)

where, items s/y_1 and t/y_1 are relative wave length and relative wave height of roughness. As the height of roughness (t) is the same for all the rough beds, therefore, the parameter t/y_1 can also be neglected to drive the following function:

$$\frac{y_2}{y_1} = f_4\left(\text{Fr}_1, \frac{s}{y_1}, \frac{L_{\text{rou}}}{y_1}\right)$$

Eq.(5)

Ultimately the general form of the above equation is written as follows:

$$\frac{y_2}{y_1} = a \text{Fr}_1^b \left(\frac{s}{y_1}\right)^c \left(\frac{L_{\text{rou}}}{y_1}\right)^d$$

Eq. (6)

in which, the item y_2/y_1 is dependent and Fr_1 , $L_{\text{rou}}y_1^{-1}$ and $s y_1^{-1}$ are independent terms. The coefficients, a, b, c and d, as indicated in Table 4, were found using SPSS software. In this table, the variations of sequent depth are shown with respect to independent variables. The statistical analysis shows a good relationship between y_2/y_1 and independent variables for all the cases, due to high regression values and low standard errors of estimate. However, the difference among the values of regression coefficient and standard error of estimates for all the cases is not significant. Thus, it can be concluded that the influence of items $L_{\text{rou}}y_1^{-1}$ and $s y_1^{-1}$ can be ignored and y_2/y_1 can be written as only a function of Froude number, Fr_1 .

Table IV. The coefficients of function 6 with statistical analysis

Equations	Coefficients				R ²	Std. Error of Estimate
	a	b	c	d		
$\frac{y_2}{y_1} = f_4\left(\text{Fr}_1, \frac{s}{y_1}, \frac{L_{\text{rou}}}{y_1}\right)$	1.1	1.069	0.073	-0.064	0.996	0.0064
$\frac{y_2}{y_1} = f_4\left(\text{Fr}_1, \frac{s}{y_1}\right)$	0.9	1.047	0.04	-	0.968	0.0186
$\frac{y_2}{y_1} = f_4(\text{Fr}_1)$	0.96	1.091	-	-	0.964	0.0195

Like the sequent depth, the dimensional analysis of the factors affecting on the hydraulic jump length was derived giving the following equation:

$$\frac{L_j}{y_1} = f_5\left(\text{Fr}_1, \frac{s}{y_1}, \frac{L_{\text{rou}}}{y_1}\right)$$

Eq.(7)

Again on the base of Buckingham theorem, the general form of the above equation is as follows:

$$\frac{L_j}{y_1} = a_1 \text{Fr}_1^{b_1} \left(\frac{s}{y_1}\right)^{c_1} \left(\frac{L_{\text{rou}}}{y_1}\right)^{d_1}$$

Eq.(8)

in which, the item L_j/y_1 is dependent and Fr_1 , $L_{\text{rou}}y_1^{-1}$ and $s y_1^{-1}$ are independent variables. The coefficients, a_1 , b_1 , c_1 and d_1 , as indicated in Table 5, were also found using SPSS software. In this table, the variations of the length of roughness are shown with respect to independent variables. The statistical analysis showed a good relationship between L_j/y_1 and independent variables, Fr_1 , $L_{\text{rou}}y_1^{-1}$ and $s y_1^{-1}$, due to the high regression values and the low standard errors of estimate for this case.

Table V. The coefficients of equation 8 with statistical analysis

Equations	Coefficients				R ²	Std. Error of Estimate
	a ₁	b ₁	c ₁	d ₁		
$\frac{L_j}{y_1} = f_5\left(\text{Fr}_1, \frac{s}{y_1}, \frac{L_{\text{rou}}}{y_1}\right)$	3.4	1.18	0.16	-0.147	0.94	0.031
$\frac{L_j}{y_1} = f_5\left(\text{Fr}_1, \frac{s}{y_1}\right)$	2.8	1.13	0.09	-	0.84	0.05
$\frac{L_j}{y_1} = f_5(\text{Fr}_1)$	2.6	1.23	-	-	0.828	0.05

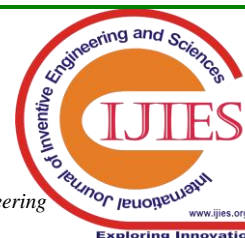

B. Water surface profile

Figure 4 shows the water surface profiles of all running tests in this study. To draw these profiles, water depths were measured every 5 centimeters from the beginning to the end of hydraulic jump over three types of roughness A, B and C. The depths (y) were normalized $((y - y_1)/(y_2 - y_1))$ using conjugate depths y_1 and y_2 and the distances were did with respect to jump length (L_j). According to this figure, all the profiles follow the same trend line and water depth increases over distance from the beginning of jump. The reduction of water depth with roughness promotion is clear in this figure.

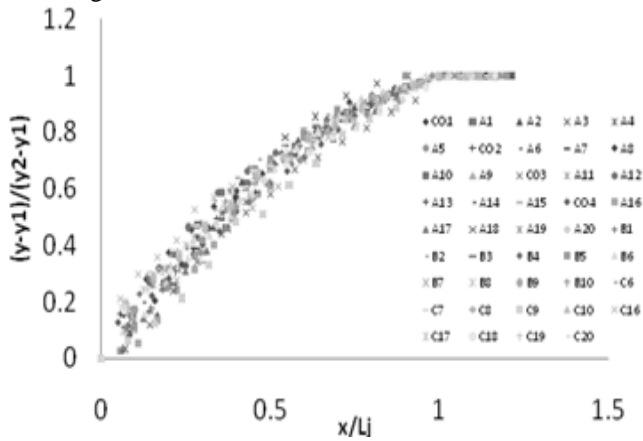

Fig. IV. Water surface profile over distance

C. Variatons of jump dimensions with rough length

Figure 5 shows the variations of relative depth reduction factor ($D = (y_{co} - y_2) y_{co}^{-1}$) with respect to the normalized length of rough bed ($L_{rou}L_{jco}^{-1}$) which are called, A, B, C and D sheets. In this figure, y_{co} is sequent depth on the smooth bed, L_{rou} is the rough jump length and L_{jco} is the smooth jump length in every experiment. As shown in this figure, D increases with increasing ($L_{rou}L_{jco}^{-1}$) and finally gets a constant value at which the rough bed length is equal to the effective roughness length. Overall, in this study, the values of relative depth reduction factors (D) at the effective rough length are in the range of 0.104 to 0.181 with the average value of 0.141. This average value, as reported by Ead and Rajaratnam (2002), was 0.25 and it was 0.20, as recorded by Tokyay (2005) and Izadjoo and Shafai Bejestan (2007). The reason for the difference between the value obtained in this study and those reported by others might be due to rough height value which was 40 % smaller in this study. In order to find the effect of roughness on the length of jump, the values of relative length factors (L_j^*) was defined as follows:

$$L_j^* = \frac{L_{jco} - L_j}{L_{jco}} \quad \text{Eq. (9)}$$

where L_{jco} is the length of jump on the smooth bed and L_j is the length of jump on the rough bed at every experiment.

D. The effective length of rough bed

As it was already mentioned, the effective length of rough bed is the maximum length beyond which no changes in the jump features will be occurred. The results of this research, however, showed that the effective rough lengths for the

As indicated in Figure 6, L_j^* increases with increasing relative roughness length ($L_{rou}L_{jco}^{-1}$) and finally reaches to a constant value, where the rough bed length is equal to the effective rough length.

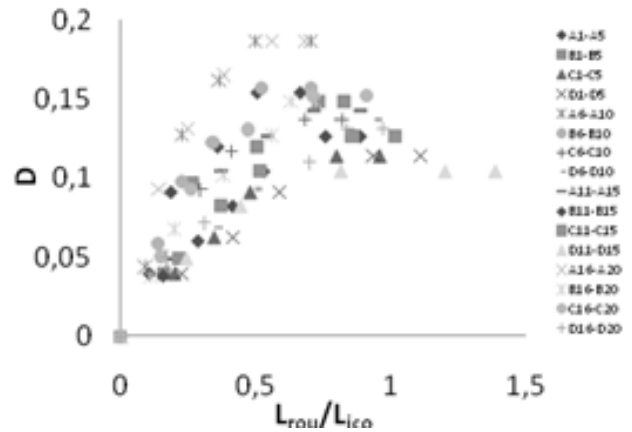

Fig. V. Variations of relative depth reduction factor, D over L_{rou} / L_{jco}

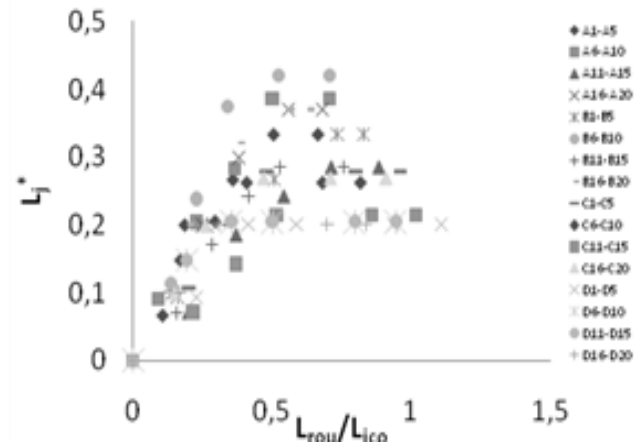

Fig. VI. Variations of relative length factors, L_j^* over L_{rou} / L_{jco}

In this study, the values of relative length reduction factors (L_j^*) at the effective rough length are in the range of 0.20 to 0.42 with the average value of 0.29, compare to those obtained by other investigators such as Abbaspour et al. (2009) and Izadjoo and Shafai Bejestan (2007) who reported 0.50 and Tokyay (2005) who suggested 0.35 value. The reason for the difference between the value obtained in this research and those reported by others seems to be due to the shortness of rough height in this study, i.e. 1.5 cm, compared to the other value which was 2.5 cm. The steep slopes of D and L_j^* diagrams for rough bed data, as shown in Figures 5 and 6, represent the more impact of rough bed initiation on the relative depth reduction factor and relative length factors.

jump length and the sequent depth were different. The relative effective rough length was determined by dividing the effective rough length (L_{rou}) to the sequent depth obtained on the smooth bed (y_{co}).



Assessment of Rough Bed Length Variations on the Hydraulic Jump Features

Figure 7 shows the variations of relative effective rough length ($L_{rou}^* y_{co}^{-1}$) with Froude numbers for different rough sheets and constant sequent depth. As shown in this figure, the sequent depth reduces as the Froude number increases and also when the rough sheets change from A to D, the rough wave length (s) increases. In this study, the values of relative effective rough length for different rough sheets and sequent depth ranged from 2.15 to 4 with the average value of 3. Figure 8 shows the variations of relative effective rough length with Froude numbers for the jump length and for different rough sheets. As shown in this figure, the relative effective rough length reduces as the Froude number increases and as the rough sheet changes from A to D for the jump length. The magnitude of relative effective rough length for jump length ranged from 1.31 to 3.14 with the average value of 2.07. Overall, the mean value of relative effective length for both the jump length and the sequent depth were estimated to be 2.5 times of sequent depth on the smooth bed

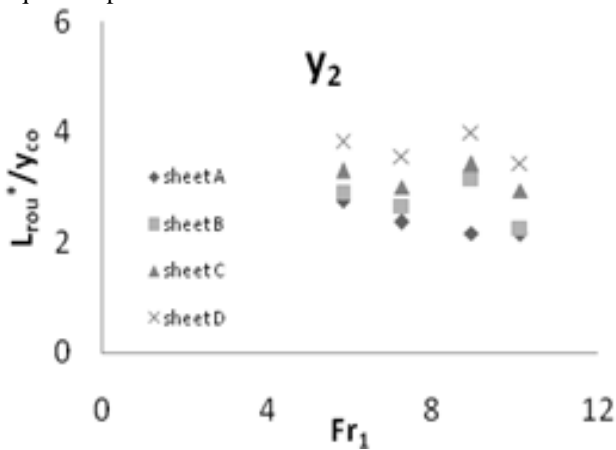

Fig. VII. Variation of effective rough length with Froude number for different rough sheets and sequent depth

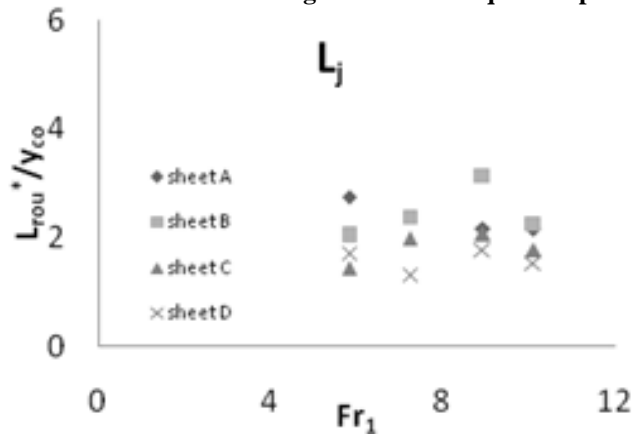

Fig. VIII. Variation of effective rough length with Froude number for different rough sheets and jump length

E. Rough bed shear stress

The main reason for reduction of both the sequent depth and the length of hydraulic jump was the growth of shear stress created on the rough bed. To determine the shear stress on the wavy bed, the momentum equation was used. This equation for the reach limited between the beginning and the end of jump is written as follows:

$$(M_2 + P_2 - S_2) = (M_1 + P_1 - S_1) - \int_{x_1}^{x_2} \tau_b dx \quad \text{Eq. (10)}$$

where S_1 , S_2 , M_1 , M_2 , P_1 and P_2 are the normal shear stress, momentum force and pressure force at the sections respectively before and after the jump and τ_b is the bed shear stress. If the normal shear stress is ignored in this equation, then the shear force of bed, F_τ , is derived using following equation:

$$F_\tau = \int_{x_1}^{x_2} \tau_b dx = (P_1 - P_2) + (M_1 - M_2) \quad \text{Eq. (11)}$$

in which P_1 , P_2 , M_1 and M_2 can be found using the equations: $P_1 = 0.5\gamma y_1^2$, $P_2 = 0.5\gamma y_2^2$, $M_1 = \rho u_1^2 y_1$ and $M_2 = \rho u_2^2 y_2$, where y_1 and y_2 are depths and u_1 and u_2 are velocities at sections 1 and 2 and γ and ρ are specific weight and density of water, respectively. The shear stress factor, ϵ , on the smooth and wavy rough bed can be found using the equation offered by Ead and Rajaratnam (2002) as follows:

$$\epsilon = \frac{F_\tau}{\gamma y_1^2 / 2} \quad \text{Eq. (12)}$$

Figure 9 shows the variation of estimated shear stress factor versus length of rough bed for all the tests performed in this study. According to this figure, the values of relative shear stress factor increases non linearly and reaches to the peak values. As indicated in this figure, the higher values of shear stress factor obtained at higher Froude numbers. Figure 10 is a representative of shear stress variation with the Froude number for both smooth and rough beds for the effective roughness length. As indicated in this figure, the fitted shear stress trend line for the data collected on the rough bed increases with Froude number and it is above the smooth bed line. This is because of shear stress growth on the rough bed. The following equation shows the relationship between the shear stress factor, ϵ , with the Froude number for the effective length.

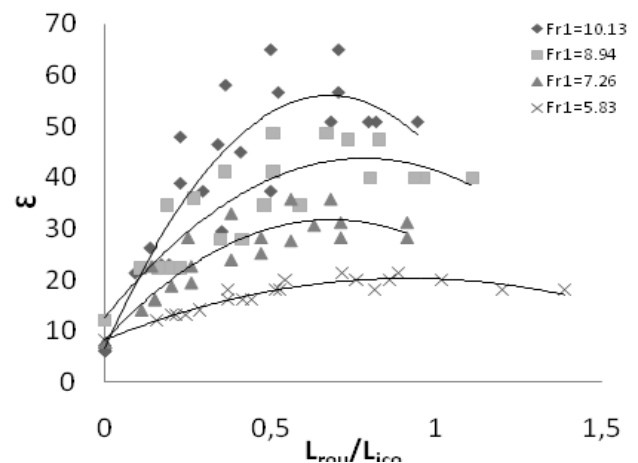

Fig. IX. Variation of shear stress factor with the length of roughness

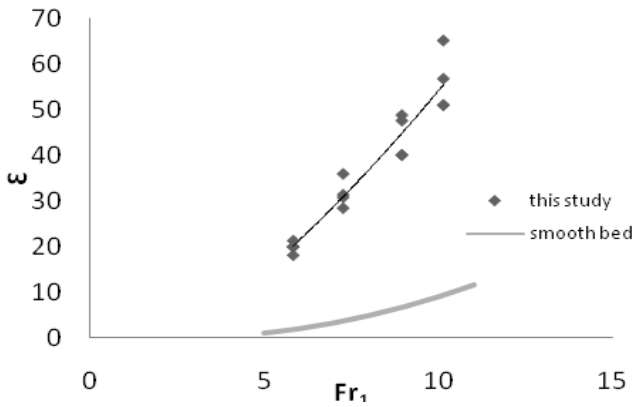

Fig. X. Variation of shear stress factor with Froude number for the effective rough length

$$\varepsilon = 0.240 Fr_1^2 + 4.429 Fr_1 - 13.96$$

$$R^2 = 0.923 \quad \text{Eq. (13)}$$

The relative shear stress is defined as the ratio of shear stress on the rough bed to the shear stress on the smooth bed. The mean value of relative shear stress in this study is 8.11 for the length equals to the effective length. The relative shear stress value, found by Izadjoo and Shafai Bejestan (2007) and Ead and Rajaratnam (2002)], was 10 times of shear stress on the smooth bed. The discrepancy between the relative shear stress value in this study and the values

reported by the others is due to the lower value of rough height in this research which was 40% smaller than those reported by Izadjoo and Shafai Bejestan (2007) and Ead and Rajaratnam (2002).

IV. CONCLUSIONS

The conclusions drawn from this study are as follows:

- 1- The jump characteristics including jump length and sequent depth reduced as the rough bed length increased. On the average, the sequent depth and the jump length reduced by 14 and 29 % respectively. These variations are limited to the effective length of roughness, where no change takes place as the length increases.
- 2- On the average, the ratio of effective rough length to both sequent depth and jump length were 3 and 2.07, respectively. The mean value of these figures was 2.5, which might stand as effective length factor for the hydraulic jump.
- 3- The shear stress on the rough bed increased with increasing rough bed lengths and Froude numbers. These variations were also limited to the effective length of roughness. On the average, the mean shear stress value on the rough bed is 8.11 times that of the smooth bed.
- 4- Rough bed dissipates more energy than a smooth bed through a hydraulic jump conditions.

Symbols

symbol	unit	description	symbol	unit	description
D	-	relative depth	S	%	slope
Fr	-	Froude number	$u_1 \ \& \ u_2$	m/s	velocity
F_b	N	shear force for bed	y_1	mm	initial depth
g	m/s^2	gravity	y_{co}	mm	sequent depth
L_j	m	length of hydraulic jump	ε	-	shear stress factor
L_j^*	m	relative length factor	γ	N/m^3	specific weight
L_{jco}	m	jump length on smooth bed	ρ	Kg/m^3	density
L_{rou}	m	jump length on rough bed	τ	N/m^2	normal shear stress
$M_1 \ \& \ M_2$	N	momentum	τ_b	N/m^2	bed shear stress
$P_1 \ \& \ P_2$	N/m^2	pressure	μ	$N.s/m^2$	dynamic viscosity
Q	L/s	flow rate	ν	m^2/s	kinematic viscosity
Re	--	Reynolds number			

REFERENCES

1. Abbaspour, A., Farsadizadeh, D., Ghorbani, M.A., "Estimation of hydraulic jump on corrugated bed using artificial neural networks and genetic programming," *Water Science and Engineering*, 2013, 6(2), 189-198.
2. Abbaspour, A., Hosseinzadeh Dalir, A., Farsadizadeh, D. Sadraddini, A.A., "Effect of sinusoidal corrugated bed on hydraulic jump characteristics," *Applied Sciences*, 2009, 9(11):2045-2055.
3. Azizah, G., Yousif N. Mostafa S., "Hydraulic jump on new roughened beds," *Asian Journal of Applied Sciences*, 2012, 5 (2): 96-106.
4. Ead S.A., Rajaratnam, N., "Hydraulic jumps on corrugated bed. *Hydraulic Engineering*," 2002, 128(2):656-663.
5. Izadjoo F., Shafai Bejestan, M., "Corrugated bed hydraulic jump stilling basin," *Applied Sciences*, 7(8):1164-1169.
6. Rajaratnam, N., 1968. Hydraulic jump on rough bed. 2007, *Trans. Eng. Inst. Canada* 11:18.
7. Tokyay N.D., "Effect of channel bed corrugations on hydraulic jumps," EWRI. Water & Environmental Resources Congress. Anchorage, Alaska. USA. 2005.
8. Chow V.T., "Open Channel Hydraulics," McGraw-Hill, New York, 1959.
9. USBR., "Design of small dams," Denver. USA, 1987.
10. Sun Z.H. and Ellayn A., 2012. Effect of prismatic elements as bed roughness on hydraulic jump characteristics *International Journal of the Physical Sciences*, 2012, 7(17): 2607 – 2615.