

Resonance Circuits and Applications

Manal Abdul Ameer Qabazard

Abstract—This paper presents and reviews the series and Parallel Resonance Circuits starting from the concept of circuit impedance and how does resonance occur then studying the circuits of each type and its characteristic , then finally some of important applications of each type.

Index Terms— Circuit Impedance, Resonance, Ideal inductor and Ideal Capacitor, Series Resonance Circuits Band Width , Parallel Resonance Circuits ,Applications of series and parallel resonance circuits.

I. INTRODUCTION

The purpose of this introduction is to Review the combination of resistive, inductive and capacitive circuits and the concepts of impedance, quality factor or 'Q', and resonant circuits.

IMPEDANCE(Z)[1],[2]

Impedance is the total opposition to current flow in an AC circuit.

Impedance is the opposition to current flow in an AC circuit and is measured in ohms. There is no inductive or capacitive reactance in a DC circuit. However, in an AC circuit there is resistance, inductive and capacitive reactance. All of these oppose current flow and the combined opposition to current flow is called impedance.

It is important to remember that any circuit can be reduced to a resistance and either a single inductive or capacitive reactance

A circuit cannot be inductive and capacitive at the same time. The effect of inductive reactance on current is to cause the current to lag the voltage. The effect of capacitive reactance is to cause the current to lead the voltage. Both of these effects are opposite.

Therefore, the circuit will either be capacitive or inductive, but not both.

If you have trouble remembering which leads and lags, remember this:

L is for inductance - L is for Lag.

(That is, current lags the voltage in an inductive circuit)

Complicated circuits with lots of resistors, capacitors and inductors can be reduced to a single resistance and a single reactance, either capacitive or inductive. The circuit below is a series RLC circuit. Since the inductive reactance is 100 ohms and the capacitive reactance is 50 ohms, the net reactance of the circuit is 50 ohms of

inductive reactance.

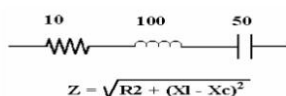

The impedance of the above circuit is 10j50 ohms.

WHEN $X_L = X_C$

When a circuit contains exactly the same amount of inductive and capacitive reactance, the net reactance is zero and the circuit is resistive.

So if a circuit contains 100 ohms of resistance in series (or parallel) with 200 ohms of inductive reactance and 200 ohms of capacitive reactance, the impedance of the circuit is 100j0 or simply 100 ohms.

Resonance In Electric Circuits:

Any passive electric circuit will resonate if it has an inductor and capacitor ,Resonance is characterized by the input voltage and current being in phase. The impedance (or admittance) is completely real when this condition exists.

Basically ,there are two types of resonant circuits :

- (a) series resonance.
- (b) parallel resonance.

II. IDEAL INDUCTOR AND CAPACITOR IN SERIES [3],[4]

Consider an inductor and a capacitor connected in series as shown in Fig.1 below. In this case the same current flows through both elements so that $I_L = I_C$. If this is taken as reference zero phase, then it can be seen that the voltage across the inductor leads the current so that it appears 90o ahead of it in the phasor diagram of Fig. 1. On the other hand, the voltage across the capacitor lags the current so that it appears 90o behind on the phasor diagram. It can be seen therefore that the voltages across the inductor and the capacitor are in antiphase or 180o out of phase with each other. The relative magnitudes of the voltages are different and depend on the values of the inductance and capacitance of these elements at the particular frequency of excitation

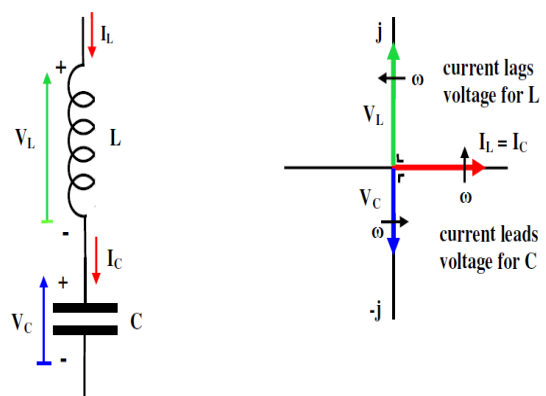

Fig. 1 An Inductor and Capacitor Connected in Series

Manuscript Received on March 2015.

Manal Abdul Ameer Qabazard, P o box 1211, Al jabriah Kuwait-46313, Kuwait.

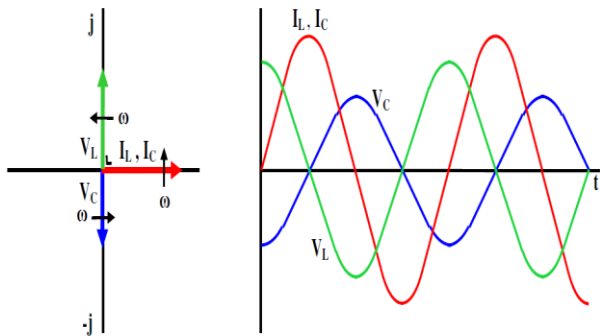

Fig. 2 Phasor Diagram and Waveforms for Inductor and Capacitor in Series

Waveforms are shown for sinusoidal excitation of the circuit in Fig. 2. From this it is clearly evident that the phasors representing the voltages across the inductor and the capacitor are exactly 180° out of phase, showing excursions on opposite sides of the abscissa axis. The difference in the amplitudes depends on the relative magnitudes of the impedances as functions of frequency and hence also on the values of inductor and capacitor used. The impedance of the series combination can be found in the normal manner. As the elements are in series, the currents through both elements are identical and the voltage drop across the series combination is the sum of the voltage drops across the individual elements. Then the impedance is given as:

$$Z = \frac{v(t)}{i(t)} \quad \text{where} \quad v(t) = v_L(t) + v_C(t)$$

Then:

$$Z = \frac{v_L(t) + v_C(t)}{i(t)} = \frac{v_L(t)}{i(t)} + \frac{v_C(t)}{i(t)} = Z_L + Z_C$$

$$Z = j\omega L - j\frac{1}{\omega C} = j\left(\omega L - \frac{1}{\omega C}\right)$$

It can be seen that the overall impedance of the network is purely reactive with no resistance, in the case of the ideal inductor and capacitor implied in Fig. 1. Given the nature of the above expression, there is clearly a value of frequency for which the expression is zero. This can be found as:

$$\omega L - \frac{1}{\omega C} = 0$$

$$\omega L = \frac{1}{\omega C}$$

$$\omega^2 = \frac{1}{LC}$$

$$\omega = \omega_0 = \frac{1}{\sqrt{LC}}$$

The value of this frequency, referred to in practice as the resonant frequency, depends entirely of the values of the components used. This result implies that at this frequency the impedance of the series combination is zero in the case of ideal components. The magnitude of the impedance is given as:

$$|Z| = \omega L - \frac{1}{\omega C}$$

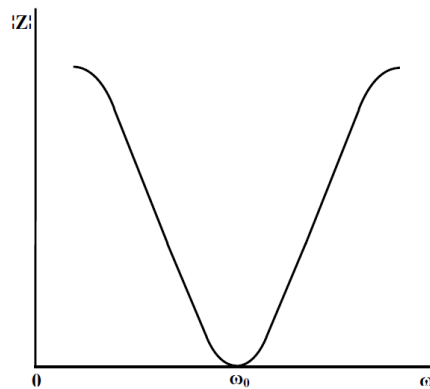

Fig. 3 The Magnitude of the Impedance as a Function of Frequency

This is shown plotted as a function of frequency in general form in Fig. 3. It can be seen that the impedance is very high at high and low frequencies. It becomes zero at the resonant frequency $\omega = \omega_0$.

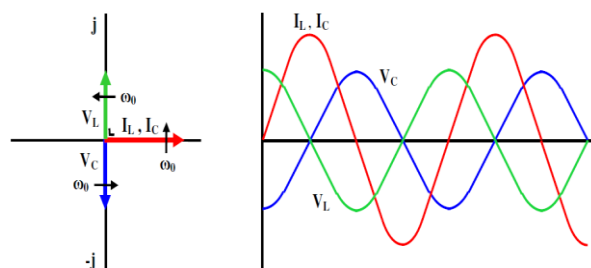

Fig. 4 Phasors / Waveforms for Series Inductor and Capacitor at Resonance

In essence, at the resonant frequency the effect of the inductive reactance cancels the capacitive reactance. Therefore the same current develops voltages with equal magnitude and opposite polarity at the resonant frequency and the net effect is zero voltage or potential drop across the combined series combination, giving the resultant net impedance of zero as shown in Fig. 3. It must be noted, however, that the individual voltages across each element are not zero as can be seen in Fig. 4 where the phasor diagram and waveforms are shown at the resonant frequency. The precise magnitudes of the voltages across the capacitor and the inductor depend on the values of these components, the inductance in Henrys and the capacitance in Farads.

III. RESISTANCE, INDUCTOR AND CAPACITOR IN SERIES[5],[6]

Fig. 5 shows a resistor added in series with the previous inductor and capacitor connected in series. Again, the same current flows through all of the elements so that $I_L = I_C = I_R$. The same relationships hold between voltage and current in the inductor and the capacitor so their phase relationships are unaltered. The voltage across the resistor is in phase with the current flowing through it so their phasors appear superimposed in Fig. 5. However, in this case the impedance has an added element in the resistor which is present. The net voltage across the circuit is the vector sum of the three individual components so that the impedance is given as:

$$Z = \frac{v(t)}{i(t)} \quad \text{where} \quad v(t) = v_L(t) + v_C(t) + v_R(t)$$

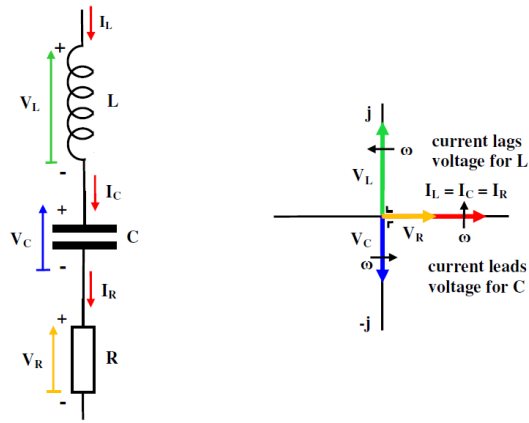

Fig. 5 A Resistor, Capacitor and Inductor, RLC, Connected in Series

Then:

$$Z = \frac{v_L(t) + v_C(t) + v_R(t)}{i(t)} = \frac{v_L(t)}{i(t)} + \frac{v_C(t)}{i(t)} + \frac{v_R(t)}{i(t)}$$

$$Z = Z_L + Z_C + Z_R = j\omega L - j\frac{1}{\omega C} + R$$

So that :

$$Z = R + j(\omega L - 1/\omega C)$$

In this case it can be seen that the impedance is truly complex, having a real part and an imaginary part. The real part is the resistance while the imaginary part is reactive. The reactive part can be dominated by the inductive reactance or the capacitive reactance depending on the values of these components and the frequency of operation. The impedance therefore has an associated magnitude and phase given as:

$$|Z| = \sqrt{R^2 + \left(\omega L - \frac{1}{\omega C}\right)^2}$$

$$\phi_Z = \text{Tan}^{-1} \frac{\left(\omega L - \frac{1}{\omega C}\right)}{R}$$

The values of both the magnitude and phase depend on the values of all of the components as well as the frequency. At the frequency $\omega = \omega_0$ having the same value as above the impedance has its minimum value. This time, however, while the reactive component becomes zero the impedance remains finite at the value of the resistance, R.

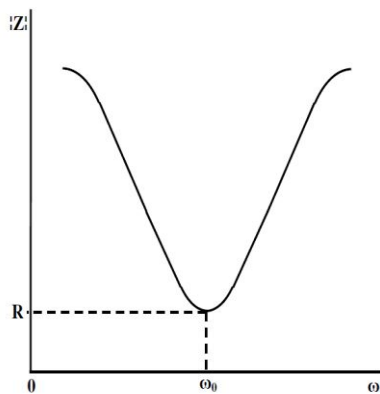

Fig.6 The Magnitude of the Impedance of the Series RLC Combination

$$v(t) = v_L(t) + v_C(t) + v_R(t) = i(t)Z = i(t)|Z|\angle\phi_Z$$

If the current phasor is taken as the reference zero phase vector then the magnitude and phase of the resultant voltage across the series RLC combination is given as:

$$v(t) = i(t)Z = I|Z|\angle\phi_Z$$

where I is the magnitude of the current. Then the magnitude and phase of the resultant voltage are obtained as:

$$|v(t)| = I \sqrt{R^2 + \left(\omega L - \frac{1}{\omega C}\right)^2}$$

$$\phi_V = \text{Tan}^{-1} \frac{\left(\omega L - \frac{1}{\omega C}\right)}{R}$$

A plot of the phasor diagram which includes the resultant voltage across the series combination is shown in Fig. 7 for particular values of components and a particular frequency. Note that the resultant net voltage across the series combination has a magnitude and phase which depends on all three components and can lead or lag the current depending on whether the net reactance is inductive or capacitive.

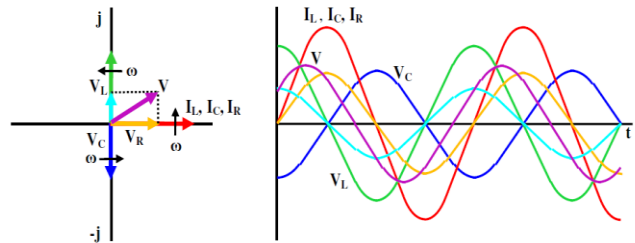
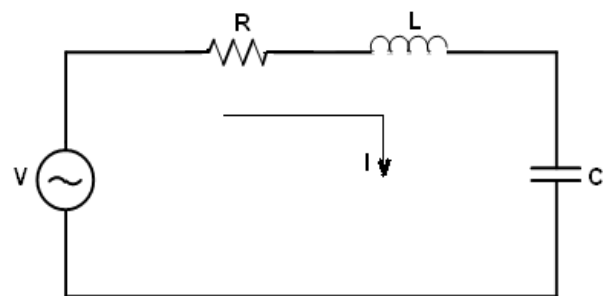

Fig. 7 Phasor Diagram and Waveforms for Series RLC Combination

IV. SERIES RESONANCE[7],[8]

Consider the series RLC circuit shown below.



The input impedance is given by:

$$z = r + j(\omega l - 1/\omega c)$$

The current in the circuit is:

$$I = V / (R + j(\omega L - 1/\omega C))$$

The magnitude of the circuit current is:

$$|I| = V_M / \sqrt{R^2 + (\omega L - 1/\omega C)^2}$$

Variation of inductive and capacitive reactance as the frequency f of the source is varied:

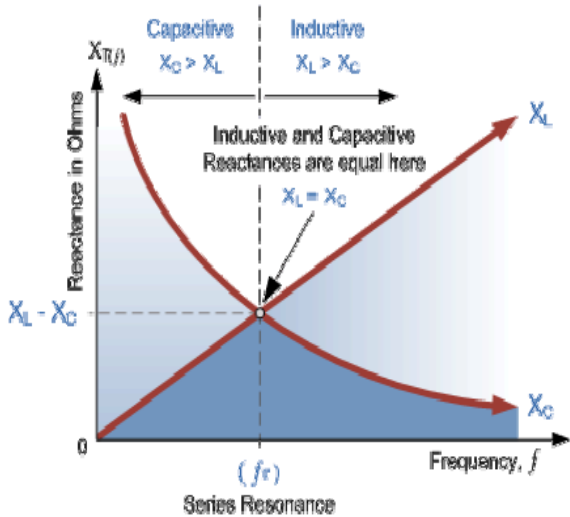

When $f = 0$, $X_L = 0$ and $X_C = \infty$.

- As f increases, the X_L increases and the X_C decreases till at a
- frequency f_r the two reactance become equal.
- With further increase in f , $\rightarrow X_L > X_C$
- At f_r the net reactance of the circuit = 0
- The impedance of the circuit $z = R$ and the current in the circuit = V/R
- f_r is known as resonance frequency and the circuit, is said to be in
- resonance.

Therefore resonance occurs when,

$$W_L = 1/W_C$$

$$W_r = 1/\sqrt{LC}$$

$$f_r = \frac{\omega_r}{2\pi} = \frac{1}{2\pi\sqrt{LC}}$$

This is an important equation, it applies series and parallel resonant circuit.

The following figure shows the variation in the impedance of the circuit as the frequency varies from 0 to ∞

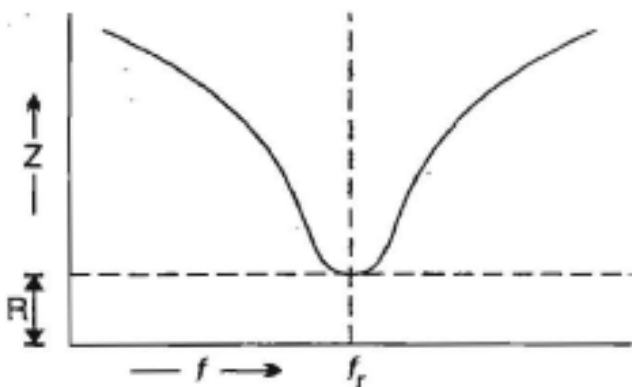

At low frequency $X_C > X_L$ and the circuit is capacitive.

As f goes on increasing, the net reactance goes on decreasing, and the impedance also goes on decreasing.

At $f = f_r$, the net reactance = 0, and the circuit impedance is the min. $Z = R$.

When $f > f_r$ $X_L > X_C$ and the circuit is inductive.

As f incr., Z is increase. too.

The variation in the magnitude is plotted in the following fig.

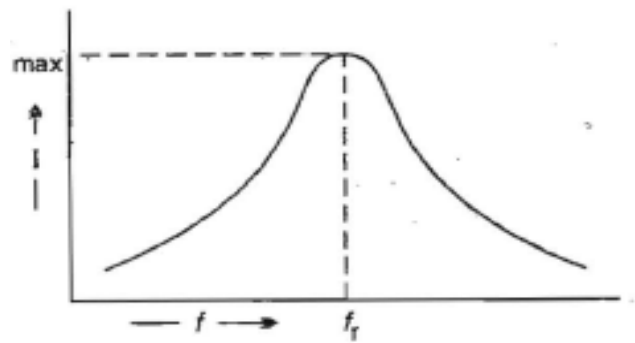

Since the current is proportional to Z , the current incr. with increasing of f .

At $f = f_r$ the current is max. (I_{max}).

As f incr. beyond f_r I decr.

The voltages across X_L and X_C are :

$$V_L = I X_L, V_C = I X_C$$

$$\text{At } f_r \quad X_L = X_C \quad V_L = V_C$$

V. SERIES CIRCUIT CURRENT AT RESONANCE [11],[12]

The frequency response curve of a series resonance circuit shows that the magnitude of the current is a function of frequency

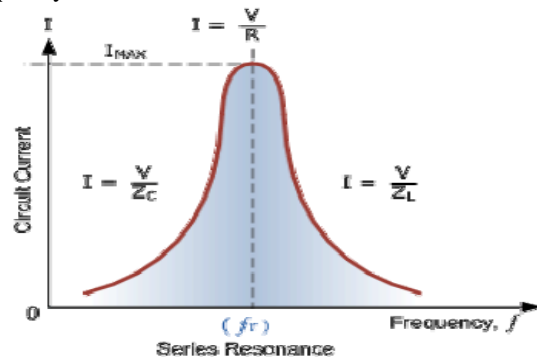

Since the current is proportional to Z , the current incr. with increasing of f .

At $f = f_r$, the current is max. (I_{max}).

• As f incr. beyond f_r I decrease.

• The voltages across X_L and X_C are :

$$V_L = I X_L, V_C = I X_C$$

$$\text{At } f_r : X_L = X_C, V_L = V_C$$

VI. BANDWIDTH OF A SERIES RESONANCE CIRCUIT [9],[10]

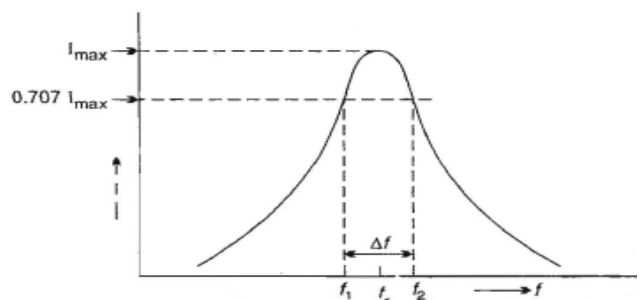

The bandwidth (B) of a series RLC circuit is :

$$BW = \Delta f = f_2 - f_1$$

• Where f_1 and f_2 are the frequencies of which the

power delivered to the circuit is 1/2 power delivered at resonance .

- These known as half power points.
- The power delivered at resonance is : $P = I_m^2 * R$

•Therefore , $0.5P = 0.5 I_m^2 * R = R(I_m/\sqrt{2})^2$

•Thus the currents I1 and I2, at half power point are: $I1 = I^2 = I_m/\sqrt{2} = 0.707I_m$

From the eq

$$|I| = V_m / \sqrt{(R^2 + (\omega L - 1/\omega C)^2)}$$

We can write

$$|I| = I_m / (1 + ((X_L - X_C)/R)^2)^{0.5}$$

$$|I| = \frac{I_m}{\left[1 + \left(\frac{X_L - X_C}{R}\right)^2\right]^{0.5}}$$

It is seen that :

$$(X_L - X_C) / R = 1$$

$$X_L - X_C = R$$

At resonance $X_L - X_C = 0$, then when freq. increase from f_r to f_2 , X_L must increase by $0.5R$ and X_C must decr. by $0.5R$ to satisfy the eq.

thus

$$2\pi f_2 L - 2\pi f_r L = 0.5R \text{ or}$$

$$f_2 - f_r = R / 4\pi L$$

Similarly when freq. decrease from f_r to f_1 ,

X_C increase by $0.5R$ and X_L decrease by the same value

, thus :

$$2\pi f_r L - 2\pi f_1 L = 0.5R \text{ or}$$

$$f_r - f_1 = R / 4\pi L$$

$$f_2 - f_1 = \Delta f = R / 2\pi L$$

$$\Delta W = R / L$$

Bandwidth of a Series Resonance Circuit

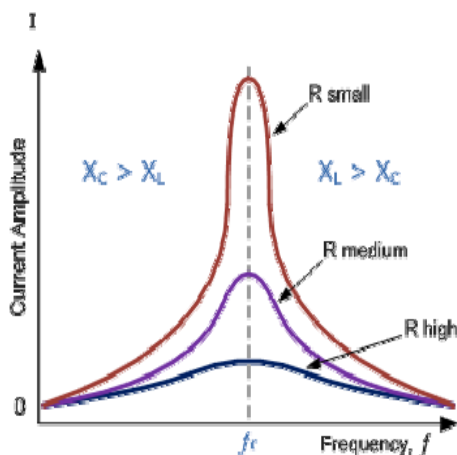

Q Factor:

The ratio of the resonance frequency to the BW is known as factor Q :

$$Q = \frac{f_r}{\Delta f}$$

$$Q = 2\pi f_r \frac{L}{R}$$

from eq. $\Delta f = R / 2\pi L$ ---

and from eq.

$$f_r = \frac{1}{2\pi\sqrt{LC}}$$

$$Q = \frac{2\pi L}{R} \left(\frac{1}{2\pi\sqrt{LC}}\right) \Rightarrow Q = \frac{1}{R} \sqrt{\frac{L}{C}}$$

Thus Q can be incr. by decr. R or by incr. L/C ratio

The following fig. shows the current versus frequency graphs for circuits with different values of Q :

A circuit with high Q has a narrow BW

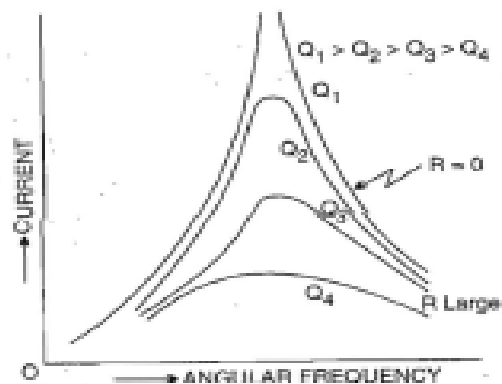

VII. PARALLEL RESONANCE

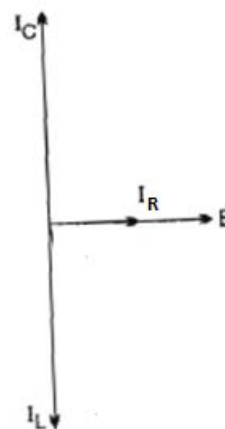
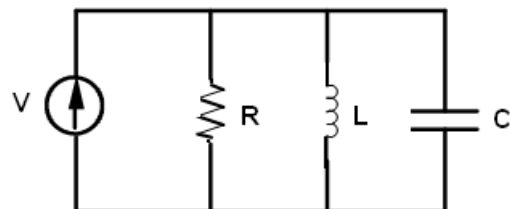

The admittance of the circuit is :

$$Y = \frac{1}{R} - \frac{j}{X_L} + \frac{j}{X_C}$$

If the source frequency is adjusted so as to make $X_L = X_C$ then

$$Y = 1/R \text{ and } Z = R, I = V/R$$

This is the condition of the parallel resonance .

The frequency f_r at which parallel resonance take place :

$$2\pi f_r = \frac{1}{2\pi f C}$$

$$f_r = \frac{1}{2\pi \sqrt{LC}}$$

IN Parallel Resonance,[13],[14]

Consider the circuits shown below:

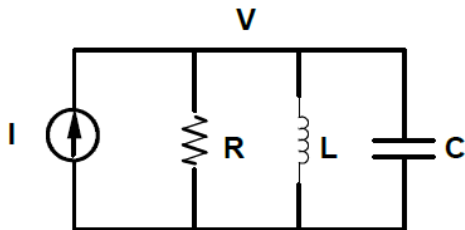

$$I = V \left[\frac{1}{R} + j\omega C + \frac{1}{j\omega L} \right]$$

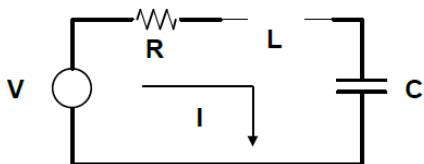

$$V = I \left[R + j\omega L + \frac{1}{j\omega C} \right]$$

Duality :

$$I = V \left[\frac{1}{R} + j\omega C + \frac{1}{j\omega L} \right] \quad V = I \left[R + j\omega L + \frac{1}{j\omega C} \right]$$

We notice the above equations are the same provided:

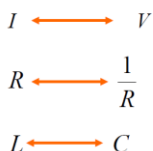

If we make the inner-change, then one equation becomes the same as the other.
For such case, we say the one circuit is the dual of the other.

Parallel Resonance[15]

What this means is that for all the equations we have derived for the series resonant circuit, we can use for the parallel resonant circuit provided we make the substitutions:

$$R \text{ replaced by } \frac{1}{R}$$

$$L \text{ replaced by } C$$

$$C \text{ replaced by } L$$

Serial Resonance

$$\omega_r = \frac{1}{\sqrt{LC}}$$

$$Q = \frac{\omega_r L}{R}$$

$$BW = (\omega_2 - \omega_1) = \omega_{BW} = \frac{R}{L}$$

Parallel resonance

$$\omega_r = \frac{1}{\sqrt{LC}}$$

$$Q = \omega_r RC$$

$$BW = \omega_{BW} = \frac{1}{RC}$$

For parallel resonant circuits, the impedance is maximum at the resonant frequency

- Total current is minimum at the resonant frequency
- Bandwidth is the same as for the series resonant circuit; the critical frequency impedances are at 0.707Zmax

The impedance of a parallel RLC circuit is maximum at resonance

- Current is minimum, and ideally equal to zero at resonance
- The phase angle is zero at resonance
- The bandwidth of a parallel resonant circuit is the range of frequencies for which the impedance is 0.707Zmax or greater

The currents in parallel L and C branches are equal in magnitude and 180° out-of-phase with each other and thus they cancel at resonance

- The critical frequencies are the frequencies above and below resonance where the circuit response is 70.7% of the maximum response
- Cutoff frequencies are also called - 3 dB frequencies or critical frequencies
- A higher Q produces a narrower bandwidth

VIII. APPLICATIONS OF SERIES AND PARALLEL RESONANCE CIRCUITS:[16]

An application using a series resonant circuit:

1-One application of a series LC circuit is the IF Trap in a superheterodyne radio receiver as illustrated in Fig. 8 below. The standard domestic AM/FM radio is such a receiver. This type of radio receiver applies a vast amount of gain to the signal picked up at the aerial in an intermediate frequency or IF stage. The intermediate frequency is chosen to lie outside the reception band of the radio. However, if a signal at this IF frequency is picked up at the aerial it can interfere severely with reception of the wanted signal. Therefore an IF Trap is included in the form of a series LC circuit which has a resonant frequency equal to the intermediate frequency. The winding of the aerial coil forms the inductance of the series circuit and its resonance with a selected capacitor value gives a near zero impedance at the IF. Therefore any signal at this frequency appearing at the aerial is shunted to ground and does not develop any detectable voltage at the input of the RF amplifier.

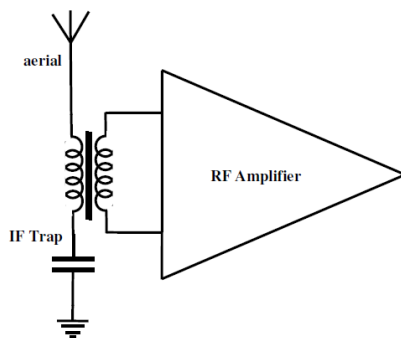

Fig. 8 A Series LC Circuit as an IF Trap in a Radio Receiver

2-Recall that at resonance a series tuned circuit has extremely low impedance. If you like you can think of it as zero impedance. Zero impedance is like a piece of conductor. If you place a conductor across the back of your TV on the terminals where the signal comes into the set, do you think you would get much of a TV picture?

I hope you said no. A short circuit on a TV antenna would stop all signals from entering the TV set and you would get squat! A series resonant circuit has zero (extremely low) impedance at one frequency only, its resonant frequency.

In figure 10 we have an interference problem from a 27 MHz CB radio getting into a nearby television set. This type of interference is called receiver overload. The problem is that the TV can't reject the 27MHz CB signal, as it is so strong and so close. We have placed a filter in the box shown on the TV cable. In that box there is a series LC circuit which is resonant on 27 MHz.

A 27MHz signal trying to get to the TV will 'see' a short circuit and will be stopped. However all other signals will be unaffected.

The interference is stopped and the TV owner can enjoy watching television

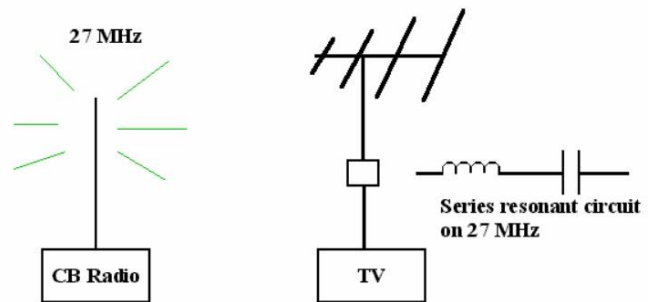

An application using a parallel resonant circuit:

The diagram Below shows an antenna connected to a parallel tuned circuit that is in turn connected to the ground.

Now, remember a parallel tuned circuit has very high impedance at one frequency only, its resonant frequency.

All of the radio waves that pass by the antenna will induce a very small voltage into the antenna. Let's say our resonant circuit is tuned to 1 MHz. An AM radio station on 1.5 MHz will cause a radio wave to pass by the antenna and induce a voltage into it. This voltage

will cause a current to flow down the antenna cable and through the tuned circuit to earth.

At 1.5 MHz the inductor and capacitor are not resonant and the impedance of the parallel circuit will be very low. $E=IR$ or if you like $E=IZ$ (Z =impedance). The voltage created across the LC parallel circuit will be very low, as its impedance is very low. The same story will go for all other radio signals that induce a voltage into the antenna EXCEPT 1MHz.

At 1MHz the LC circuit is parallel resonant and will be very high impedance. The small current through the parallel resonant circuit will produce a significant voltage across it compared to

all the other radio signals. An output voltage will appear at the output terminals of the signal that the parallel tuned circuit is tuned to. So here we have the basic method of selecting the desired radio signal from the many that are present at the antenna.

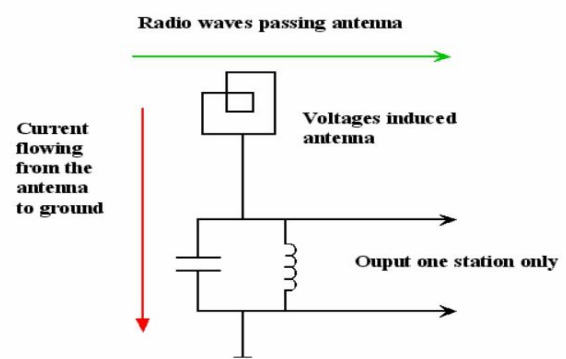

IX. CONCLUSION

The paper has presented the series and Parallel Resonance Circuits starting from the concept of circuit impedance and how did resonance occur then studied the circuits of each type and its characteristic , then finally some of important applications of each type.

REFERENCES

1. R.W. Erickson and D. Maksimovic, "Fundamentals of Power Electronics," 2nd. Edition, Kluwer Academic Publishers, 2001
2. L. P. Huelsman and P. E. Allen, Introduction to the Theory and Design of Active Filters,"McGraw Hill, 1980, ISBN: 0-07-030854-3.
3. A. I. Zverev and H. J. Blinichkoff, Filtering in the Time and Frequency Domain, John Wiley and Sons, 1976.
4. D. Hart, "Introduction to Power Electronics," Prentice Hall, 1996.
5. E. H. Watanabe, H. Akagi, M. Aredes, "The p-q Theory for Active Filter Control: Some Problems and Solutions", Trans. on Revista Control and Automation, Vol. 15 no. 1/Jan., Feb. e Maro 2004
6. A. I. Pressman, "Switching Power Supply Design," 2nd Edition, McGraw-Hill,
7. H. Zumbahlen, Passive and Active Filtering," Analog Devices AN281.
8. W. K. Chen, *Linear Networks and Systems*. Belmont, CA: Wadsworth, 1993.
9. M. E. Van Valkenburg, Analog Filter Design, Holt, Rinehart & Winston, 1982
10. K. Likharev. Single-Electron Devices and Their Applications. Proceedings of the IEEE, April 1999.
11. A. I. Zverev and H. J. Blinichkoff, Filtering in the Time and Frequency Domain, John Wiley and Sons, 1976.
12. S. Franco, Design with Operational Amplifiers and Analog Integrated Circuits, McGraw-Hill 1988, ISBN: 0-07-021799-8.
13. Aram Budak, Passive and Active Network Analysis and Synthesis, Houghton Mifflin Company, Boston, 1974.
14. R. W. Daniels, Approximation Methods for Electronic Filter Design, McGraw-Hill, New York.
15. J. R. Bainter, Active Filter Has Stable Notch and Response Can be Regulated, Electronics, Oct. 2 1975, pp.115-117.
16. A. B. Williams, Electronic Filter Design Handbook, McGraw-Hill, 1981, ISBN: 0-07-070430-9.